

SX 12/16

PSX 16

Electric Stacker Trucks
Pedestrian / Platform Version
Optional: Initial Lift
1.200 kg 1.600 kg

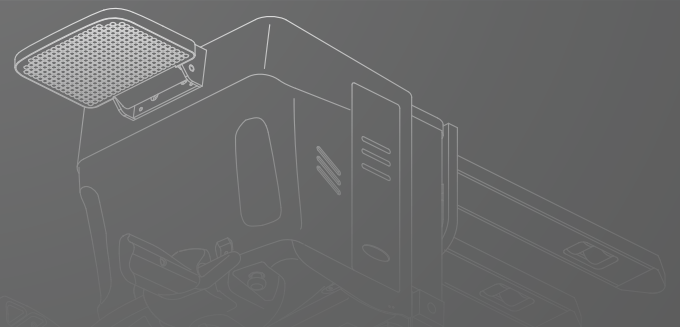
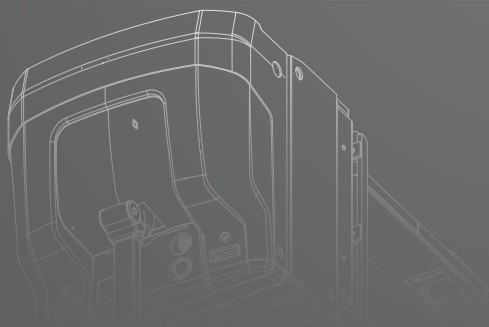
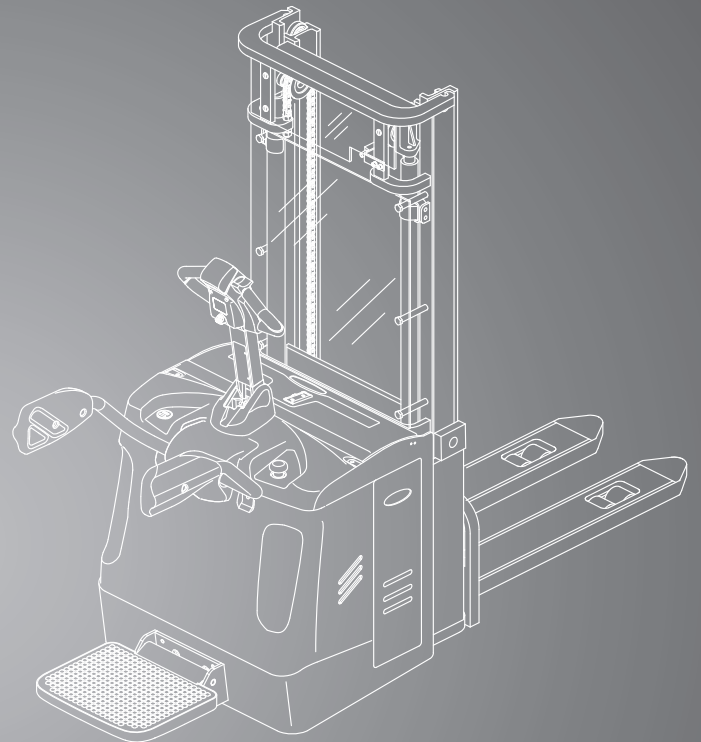
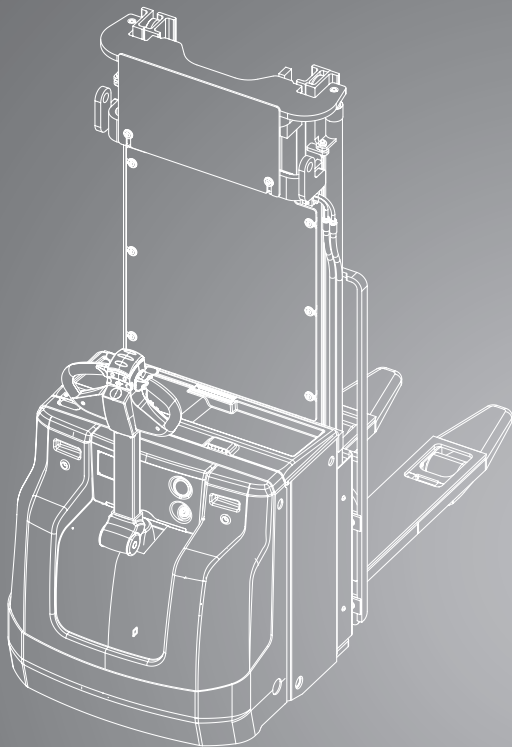

DIMENSIONS

SX12/16

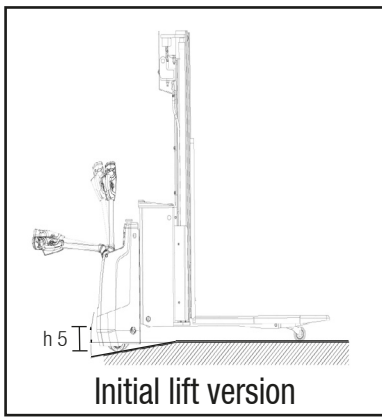

A = Brake zone
B = Drive zone

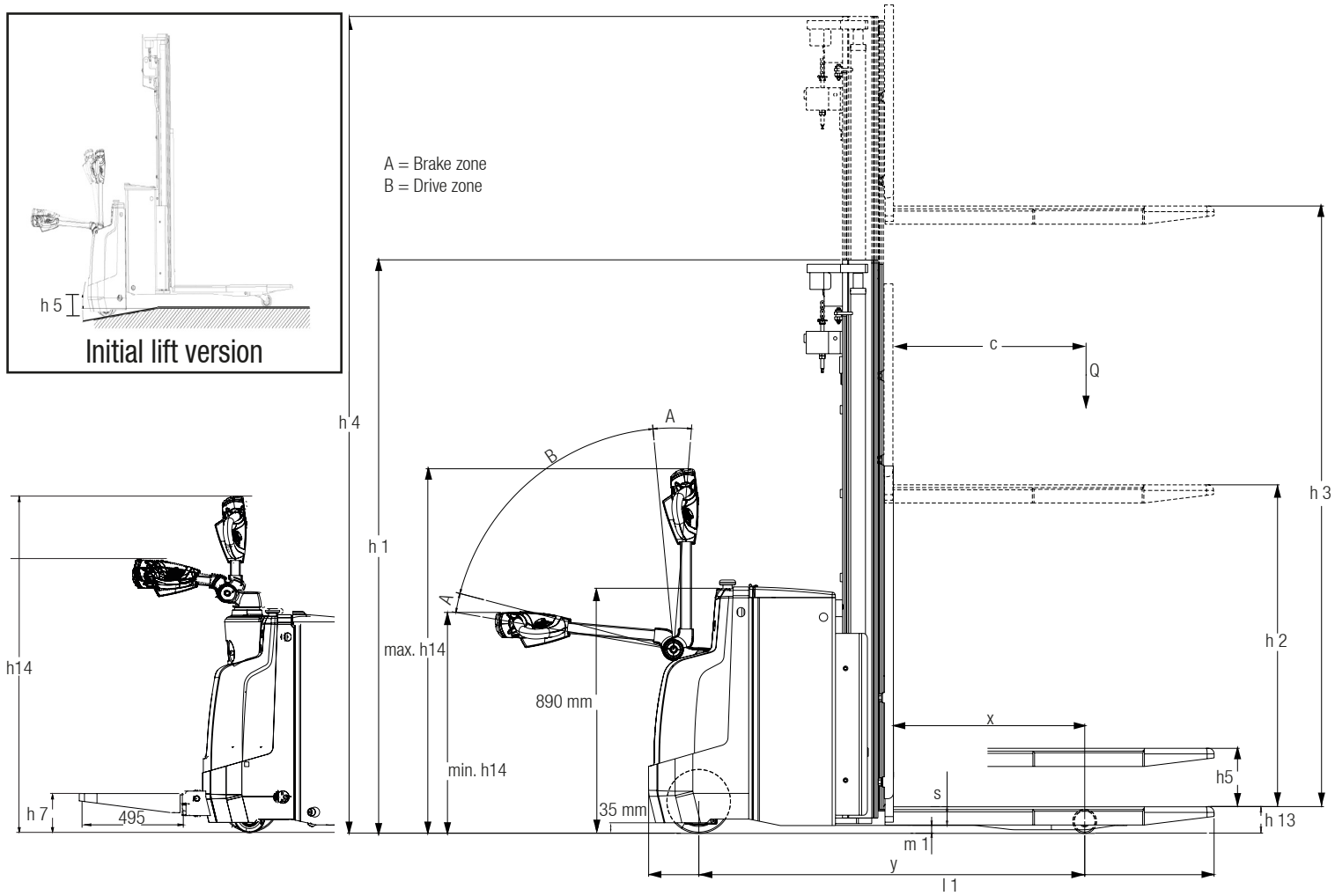

Dimensions with platform version

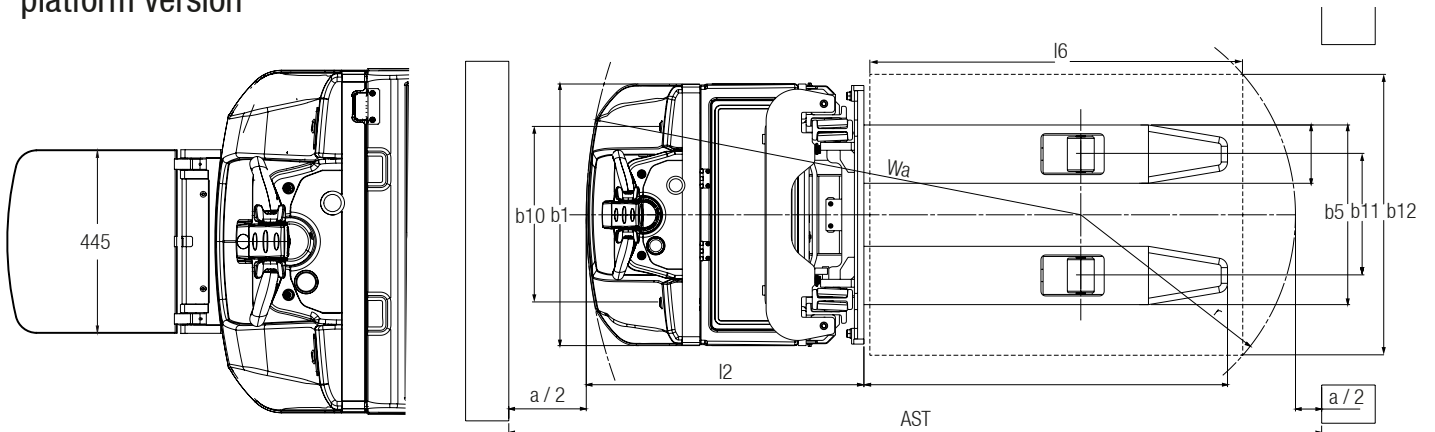

For corresponding data see specification chart.

SPECIFICATIONS



Product Specifications acc. to VDI 2198

	1.1 Manufacturer (Abbreviation)	CLARK	CLARK	CLARK	
Specifications	1.2 Manufacturer's designation	SX12	SX16	PSX16	
	1.3 Drive	24V Electric	24V Electric	24V Electric	
	1.4 Operator type *1	Pedestrian	Pedestrian	Stand-on/Pedestrian	
	1.5 Rated capacity/rated load	Q (kg)	1200	1600	1600
	1.5.1 Rated capacity/mast lift and initial lift *2	kg	600 / 600	800 / 800	–
	1.5.2 Rated capacity/support arm lift *2	kg	1200	1600	–
	1.6 Load centre distance	c (mm)	600	600	600
	1.8 Load distance	x (mm)	830	797	693
	1.9 Wheelbase	y (mm)	1361	1435	1375
Weight	2.1 Service weight incl. battery (see 6.5)	kg	920	1010	1240
	2.2 Axle loading, laden front/rear	kg	742/ 1378	738/1827	960/1880
	2.3 Axle loading, unladen front/rear	kg	653/267	707/303	860/380
Tyres, Chassis	3.1 Tyres		Polyurethane	Polyurethane	Polyurethane
	3.2 Tyre size, front		Ø 230x82	Ø 230x82	Ø 230x75
	3.3 Tyre size, rear		Ø 85x110 / 2x 85x70	Ø 85x110 / 2x 85x70	Ø 85x70
	3.4 Additional wheels (dimensions)		Ø 125 x 40	Ø 125 x 40	Ø 130x55
	3.5 Wheels, number front/rear (x = driven wheels)		1x + 2 / 2 (4)	1x + 2 / 2 (4)	1x +1/4
	3.6 Tread, front	b10 (mm)	504	504	574
	3.7 Tread, rear	b11 (mm)	385	385	370
Dimensions	4.2 Height, mast lowered	h1 (mm)	2050	2050	2020
	4.3 Free lift	h2 (mm)	125	125	100
	4.4 Lift *3	h3 (mm)	2995	2995	3000
	4.4 Lift height	h3 + h13 (mm)	3085	3085	3088
	4.5 Height, mast extended	h4 (mm)	3555	3555	3465
	4.6 Initial lift *2	h5 (mm)	110	110	–
	4.9 Height tiller in driving position min./max.	h14 (mm)	823/1246	823/1246	1150/1480
	4.8 Stand height (Optional platform for SX12/16) *1	h7 (mm)	160	160	160
	4.15 Height, lowered (Optional initial lift SX12/16)	h13 (mm)	90 (95)	90 (95)	88
	4.19 Overall length	l1 (mm)	1856	1936	2495
	4.20 Length to face of forks	l2 (mm)	706	813	879
	4.21 Overall width	b1 (mm)	830	830	850
	4.22 Fork dimensions	s • e • l (mm)	55x185x1150	65x185x1150	60x190x1150
	4.25 Distance between fork–arms	b5 (mm)	570	570	570
	4.32 Ground clearance, centre of wheelbase	m2 (mm)	28	28	28
4.33 Aisle width for pallets 1000 x 1200 sideways *5	Ast (mm)	2358	2452	2605/2965	
4.34 Aisle width for pallets 800 x 1200 lengthways *5	Ast (mm)	2303	2435	2575/2935	
4.35 Turning radius *5	Wa (mm)	1463	1589	1730/2090	
Performance	5.1 Travel speed, laden/unladen	km/h	6/6	6/6	8/8
	5.2 Lift speed, laden/unladen	m/s	0.15/0.24	0.12/0.2	0.13/0.16
	5.3 Lowering speed, laden/unladen	m/s	0.30/0.25	0.30/0.025	0.22/0.13
	5.8 Max. gradeability, laden/unladen *4	%	8/12	8/12	8/16
	5.10 Service brake		Electric	Electric	Electric
Electrics	6.1 Drive motor rating S2 60 min	kW	1.2	1.2	1.6
	6.2 Lift motor rating at S3 15 %	kW	3.2	3.2	3.0
	6.3 Battery acc. to DIN 43531/35/36 A, B, C, no		No	Yes	Yes
	6.4 Battery voltage/nominal capacity	Ah (5hr)	24 V / 150	24V / 250	24 V / 375
	6.5 Battery weight	kg	143/159	171/286	212/288
	6.6 Energy consumption acc. to VDI cycle	kg	–	–	–
	– Battery type		Traction battery	Traction battery	Traction battery
	8.1 Type of drive unit		AC	AC	AC
Misc.	10.5 Steering design		Mechanical	Mechanical	Electric servo steering
	10.7 Sound pressure level at the driver's seat acc. to EN 12053	dB(A)	68,9	68,9	74

*1) SX12/SX16 with foldable driver's platform (Optional) : Stand-on/Pedestrian *2) SX12/SX16 with initial lift (Optional) *3) Further lift heights see upright table

*4) At friction coefficient $\mu=0.6$ with 1.6 km/h *5) Platform down/ raised, dimensions relative to battery compartment (see additional table)

In accordance with VDI Guideline 2198 this specification sheet provides details on the standard truck only. Non-standard tyres, different masts, optional equipment, etc. may result in different values.

GENERAL DATA

Upright table SX12/16

Mast type	Lift height (h3+h13)	Mast lowered (h1)*	Mast extended (h4)**	Free lift (h2)
	mm	mm	mm	mm
Simplex	1515	1965	1985	1495
Standard	2585	1800	3055	125
	3085	2050	3555	125
	3385	2200	3855	125
	3585	2300	4055	125
	3790	2410	4260	125
	4090	2565	4560	125
Triplex	4065	1875	4535	1405
	4410	1990	4880	1520
	4800	2125	5270	1655
	5210	2270	5680	1800
Hi-Lo	2925	1965	3395	1495
	3215	2110	3685	1640
	3515	2265	3985	1795

* Mast lowered (h1) with initial lift (raised): +110 mm

** Mast extended (h4) with load backrest: + 750 mm

Upright table PSX16

Mast type	Lift height (h3+h13)	Mast lowered (h1)	Mast extended (h4)	Free lift (h2)
	mm	mm	mm	mm
Standard	2700	1870	3165	100
	3000	2020	3465	100
	3300	2170	3765	100
	3600	2320	4065	100
	3900	2470	4365	100
Triplex	4000	1822	4460	1390
	4500	2022	4960	1590
	4800	2122	5260	1690
	5000	2187	5460	1760
	5300	2278	5760	1840
	5500	2352	5910	1910
	5800	2452	6210	2010
Hi-Lo	2700	1820	3135	1320
	3000	1970	3435	1470
	3300	2120	3735	1620

Truck dimensions relative to battery compartment

Dimension	Model	SX12		SX16		PSX16		
		Type of change	With a crane	With a crane or side battery removal *	Side battery removal			
Battery compartment type		Small	Medium	Medium	Large	Large	XL	
Battery capacity	Ah	150	250	250	375	250 / 375	500	
1.9 Wheelbase	y mm	1361	1435	1435	1500	1375	1447	
4.19 Overall length	without platform	l1 mm	1856	1930	1936	2028	–	–
	with platform raised/lowered		1950 2356	2024 2430	2057 2463	2122 2528	2050 2575	2122 2647
4.20 Length to face of forks	without platform	l2 mm	706	780	813	878	–	–
	with platform raised/lowered		800 1206	874 1280	907 1313	972 1378	990 1395	1062 1467
4.33 Aisle width for pallets 1000 x 1200 sideways	without platform	Ast mm	2358	2423	2452	2517	–	–
	with platform raised/lowered		2452 2858	2526 2932	2546 2952	2611 3017	2640 3000	2712 3072
4.34 Aisle width for pallets 800 x 1200 lengthways	without platform	Ast mm	2281	2355	2378	2443	–	–
	with platform raised/lowered		2375 2781	2449 2855	2472 2878	2537 2943	2546 2906	2618 2978
4.35 Turning radius	without platform	Ast mm	1536	1610	1610	1675	–	–
	with platform raised/lowered		1630 2036	1704 2110	1704 2110	1769 2175	1738 2098	1810 2170
6.5 Battery weight (min/max)	kg	143/159	171/286	171/286	231/361	212/288	362/380	

* Side battery removal (for SX16 and 375 Ah battery only) – given values are not effected.

PRODUCT DESCRIPTION

SX12/16

High performance series for robust and sophisticated industrial purposes.

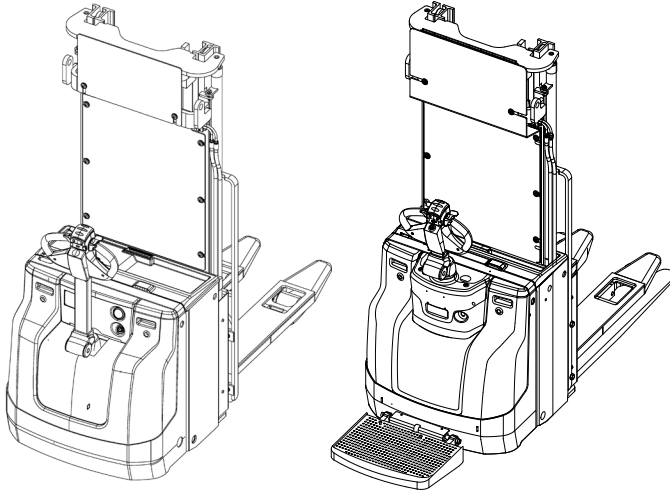

SX12/16

SX12/16 foldable driver's platform

- Enclosed upright damping (lifting and lowering)
- Motor-driven proportional hydraulic system
- Protected lift cylinders
- Foldable driver's platform (optional)
- Initial lift (optional)

PSX16

Productivity and Ergonomics for heavy-duty operation and lift heights up to 5800mm.

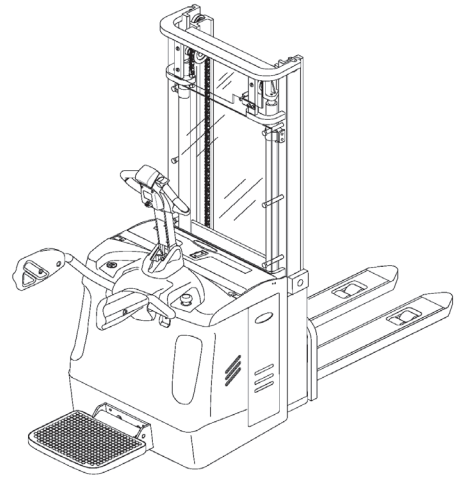

PSX16 foldable driver's platform and side safety guards

- Electric servo steering
- Pedestrian mode with folded platform and folded side safety guards
- Side battery removal (standard configuration)
- Can be equipped with batteries up to 500 Ah

DIMENSIONS

PSX16

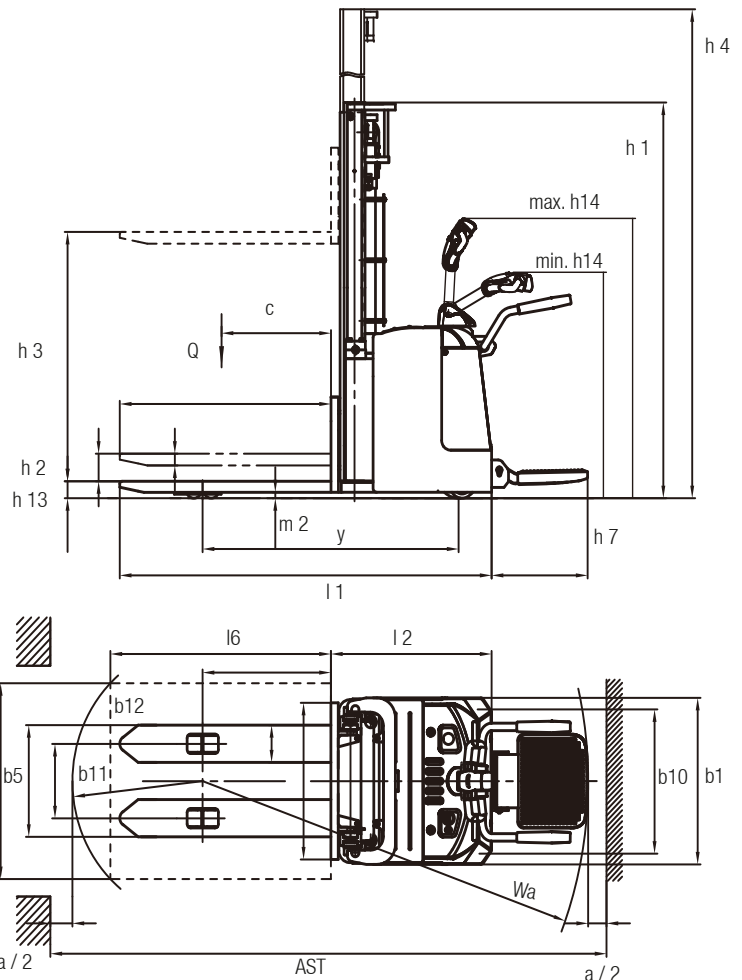

$$R_h = \sqrt{x^2 + \left(\frac{b_{12}}{2}\right)^2}$$

$$A_{st} = W_a + l_6 - x + a \text{ wenn } R_h < W_a$$

$$A_{st} = R_h + l_6 - x + a \text{ wenn } R_h > W_a$$

FEATURES & EQUIPMENT EXTRAS



		SX12/16	PSX16
General	Reliable low-maintenance AC traction motor	•	•
	Initial lift version	X	–
	Foldable driver's platform	X	•
	Side safety guards	–	•
	Proportional hydraulics system	•	•
	Enclosed upright damping (lifting)	•	–
	Enclosed upright damping (lowering)	•	•
	Protected lift cylinders	•	•
	Pallet entry wheel (for initial lift version only)	X	–
	Steel fabricated battery cover	•	•
	Large residual capacities due to 4-wheel layout	•	•
Drive and Battery Options	Single load wheel (Polyurethane)	•	X
	Tandem load wheel (Polyurethane)	X	•
	Electric servo steering	–	•
	Profiled traction wheel	X	X
	Battery discharge indicator	•	•
	Side battery removal (for SX16 and 375 Ah batteries only)	X	•
	Battery compartment sizes: 150 Ah, 250 Ah or 375 Ah batteries	X	–
	Battery compartment sizes: 250 Ah, 375 Ah or 500 Ah batteries	X	X
Miscellaneous	Key switch activation	•	•
	Pin-code activation	X	–
	Mast safety guard: PVC mast screen	•	•
	Mast safety guard: wire mesh	X	–
	Push button for operation with vertical tiller	X	–
	Load backrest (Height 1220mm / 820 width)	X	–
	Large residual capacities	•	•
	Tiller arm in a central position for symmetrical operation	–	•
	Automatic lift stop (at max. lift)	–	•
	Automatic parking brake	•	•
Safety	Comfort and safety tiller	•	•
	Crawl speed switch	X	–
	Anti-slip platform surface	•	•
	Low platform height of only 160 mm	•	•
	Automatic standby mode if the driver steps off the platform	•	•

• = Standard Equipment; x = Option; – = Not Available

CLARK Europe GmbH

Dr.-Alfred-Herrhausen-Allee 33
47228 Duisburg / Germany
Tel.: +49 (0)2065 499 13-0
Fax: +49 (0)2065 499 13-290
E-Mail: Info-europe@clarkmheu.com
www.clarkmheu.com

Dealer:

www.bakkerheftrucks.com